

**ILLUMINATOR PROLINE/EXPERTLINE  
MONOCHROME  
LED Underwater-Illumination**



**DANGER!**



**In case of improper operation outside of the water, smart lamps illuminators can get very hot. Burn hazard!**



**CAUTION!**



**The smart lamps illuminator can only be used under water for correct function. Ensure that the device is fully submerged before it is switched on, otherwise it might be severely damaged.**

## 1. Useful installation-related information

- ▶ In order to illuminate a swimming pool in an optimal way, at least 1 Watt of LED light (corresponds to 120 Lumens) should be installed per 1 m<sup>3</sup> of water.

*Example:*

A pool with 80 m<sup>3</sup> content should be equipped with two 40-Watt-illuminators.

- ▶ To avoid glare, the lights should not be placed towards the viewing direction. We recommend installing them at approx. 0.45 m below the edge of the swimming pool (see drawing).
- ▶ The installation always depends on type of pool. We generally recommend that the illuminator is installed with an smart lamps niche and flange.

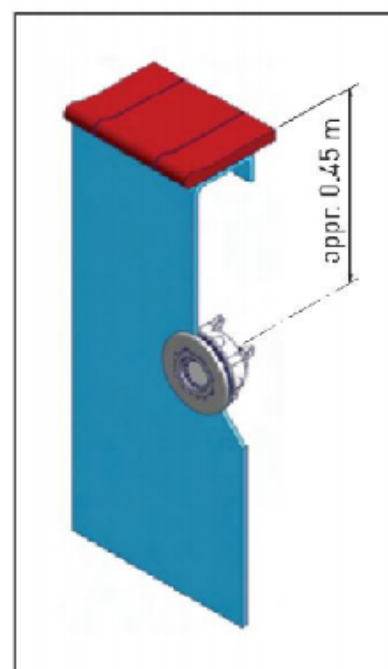

## 2. Packing list

Please check content of delivery (see drawing):

- 1 Monochrome Illuminator  $\varnothing$  94.5 mm, with 18 LED's
- 2 0.25 m cable with IP 68 male connector
- 3 O-ring for IP 68 connector
- 4 Protective sleeve
- 5 2.6 m cable with IP 68 female connector



## 3. Technical data

### 3.1 Monochrome Illuminator

Technique:	Monochrome Illuminator for security low voltage (SELV)
Protection class:	Class III / DIN 61140 / VDE0140-1
Level of protection:	IP 68
Illuminator input:	24 V, DC
Peak current:	1.7 A
Peak power input:	40 Watts
Light intensity:	$\pm$ 4,000 Lumen
Radiation ang.e:	140 degrees

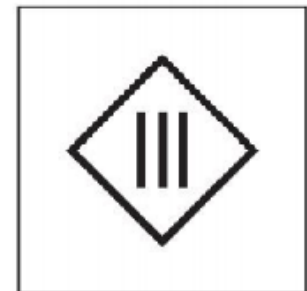

Protection class III

### 3.2 Transformer

Model type:	BL-D24V/60W
Protection class:	Class II
Level of protection:	IP 67
Mains voltage:	170-250 V / 50-60 Hz
Secondary voltage:	24 V, DC / 2.5 A
Power output:	60 Watts

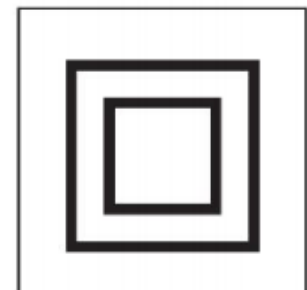

Protection class II

## 4. Declarations of conformity

### 4.1 Labels and regulations applied



BvR electronic GmbH hereby certifies on its sole responsibility that the following products are in compliance with the requirements of the:

- ☞ 2006/05/EEC Low voltage
- ☞ 2004/108/EEC Electromagnetic compatibility
- ☞ 2002/95/EEC RoHS
- ☞ DIN EN 61140 Security low voltage (SELV)

#### Tested regulations:

- ☞ DIN EN 60598-1:2005
- ☞ DIN EN 60598-2-18:1996
- ☞ DIN EN 55015: 00 + A1:01 + A2:02
- ☞ DIN EN 61000-6-3:01 + A11:04
- ☞ DIN EN 61000-3-2:06
- ☞ DIN EN 61000-6-1:01
- ☞ DIN EN 61000-4-4
- ☞ DIN EN 61547:95 + A1:00
- ☞ DIN EN 61000-4-5
- ☞ DIN EN 61000-4-11
- ☞ DIN EN 61000-4-2
- ☞ DIN EN 61000-4-6
- ☞ DIN EN 61140 (VDE 0140-1)
- ☞ DIN VDE 0100 Part 410, 412.1

## 5. Mechanical installation

### 5.1 Installation with smart lamps mounting niche

- Push the 2.6 m cable (6) at least 1 m through the provided rearside hole of the niche with the IP 68 crimp connection (5) so that the inside cable remains long enough to be drawn over the water's surface in case of a future exchange of a defect illuminator.
- Then install the niche into the wall of the swimming pool with the help of the ProLine/ExpertLine mounting flange (3), the gaskets (4) and the 10 flat head screws M10 x 25 (8). Please make sure that the area where the illuminator will be installed is flat and smooth. This is important to create a waterproof seal.



### CAUTION!



**Please apply only moderate force to the flat head screws to prevent the threads from slipping.**

- Then connect the 0.25 m cable (7) of the illuminator to the corresponding 2.5 m cable (6) in the niche. When joining both IP 68 cables, please make sure that the O-ring is attached to the male connector.
- For closing the IP 68 cable connector, turn it clockwise until it is properly locked and snapped in.
- Press the smart lamps illuminator (2) into the deepening in the middle of the mounting flange (3) and store the surplus power cable into the remaining space in the mounting niche.
- Finally, fasten the cover plate (1) to the front side of the flange with the two mushroom-shaped bolts (see detail A). Place the bolts into the holes and turn them clockwise until the bolts snap in. For this step a modest force must be applied. The enclosed special turning tool (see detail B) helps to make this easier.

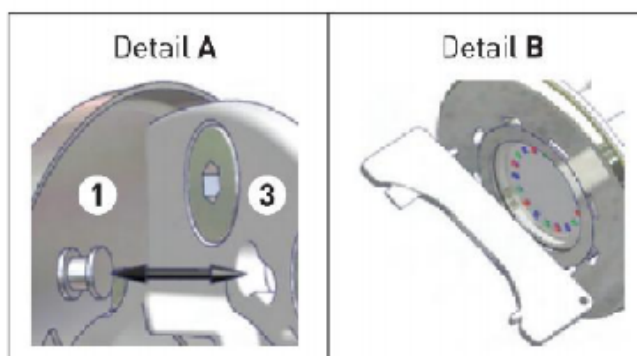
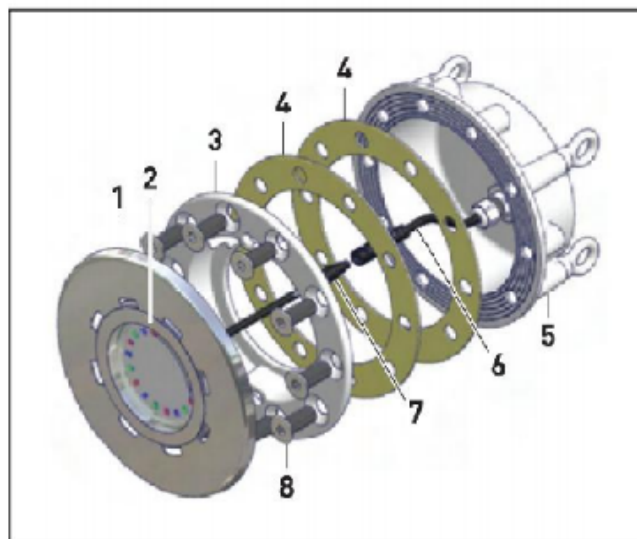

- Alternatively, an adequately sized spreading pliers can be used.

## 5.2 Installation with universal niro adapter

The universal adapter made of V4A stainless steel is used for the conversion of existing lighting systems of all kinds to smart lamps illuminators or for new installations onto a wall.

- Depending on local conditions, fix the universal adapter (6), to either the pool wall by means of dowels and stainless steel flathead screws (5), or with the aid of an optional mounting kit into the mounting holes of the existing old niche fixture.
- Place the plastic mounting flange (3) into the big central hole of the universal adapter and fix it with the enclosed five flat head screws M10 x 25 (7) and the gasket (4).
- Press the smart lamps illuminator (2) into the deepening in the middle of the mounting flange and store the surplus power cable into the remaining space in the mounting niche.

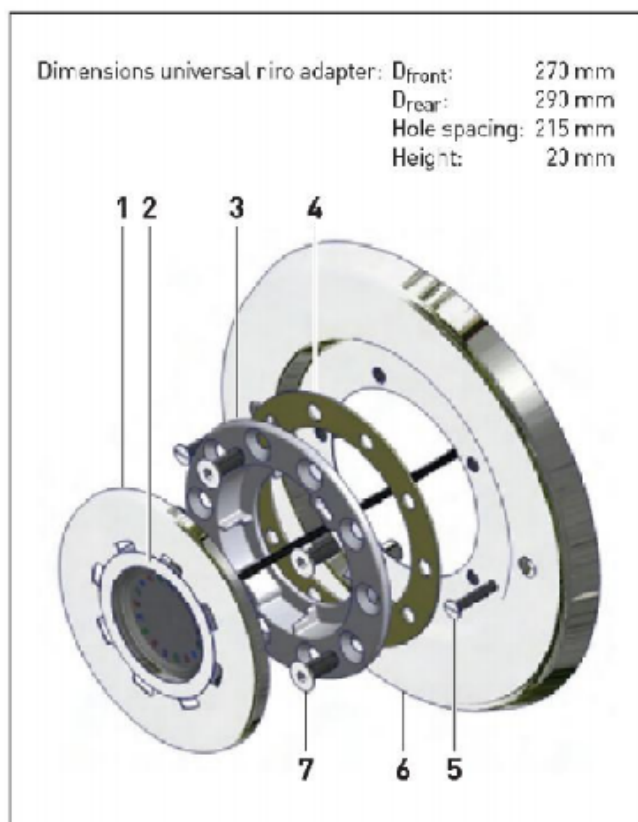

- Finally, fasten the cover plate (1) to the front side of the flange with the two mushroom-shaped bolts (see detail A) Place the bolts into the holes and turn them clockwise until the bolts snap in. For this step a modest force must be applied. The enclosed special turning tool (see detail B) helps to make this easier.

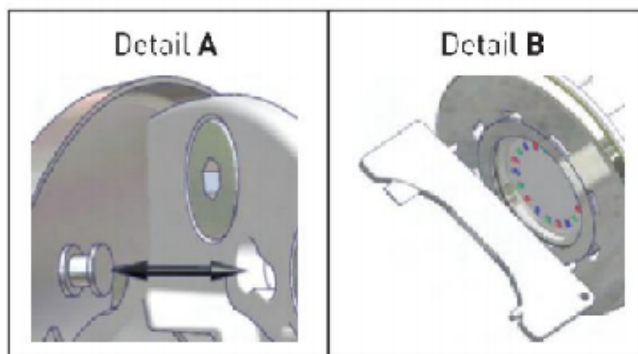

- Alternatively, an adequately sized spreading pliers can be used.

### 5.3 Installation with conversion adapter plate

The conversion adapter plate made of V4A stainless steel is used for the conversion of existing lighting systems (e.g. WIBRE or LAHME) to smart lamps illuminators.

- Place smart lamp illuminator [6] from behind in the middle hole of the conversion adapter (1) and fix it by with the mounting bracket (5), washers (4) and nuts (3) over the thread bolts (no image) on the rear side of the plate.
- Mount the fully assembled conversion adapter plate with the help of two stainless steel flat head screws (2) in place of the old illumination system. The holes are drilled in a way to be compatible to the old fastening pot.

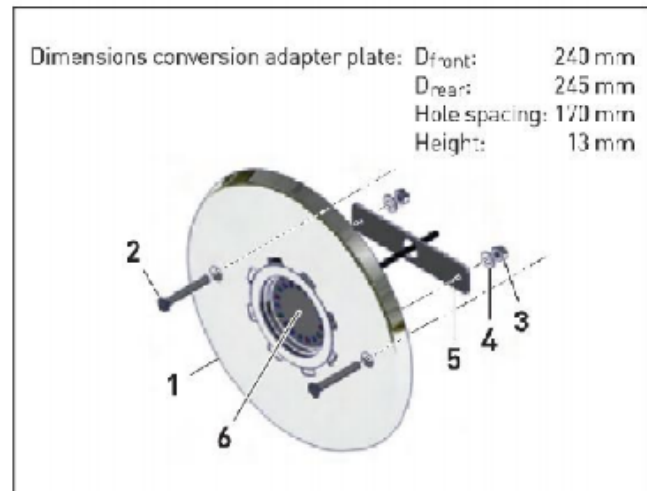

### 5.4 Conversion of aqua de-light SlimLine systems to smart lamps ProLine/ExpertLine

For the conversion of old aqua de-light SlimLine illumination systems to those of smart lamps, a special adapter kit is available.

- Fully remove the existing 10 plastic flat head screws M10 x 25 as well as the old flange and the old illumination system.
- Disconnect the IP 68 power connector. The remaining connection cable in the niche is compatible to the connector of smart lamps systems and can be re-used.
- Mount the new ProLine/ExpertLine mounting flange (2) with the deepening in the middle instead of the old flange and re-fix it to the niche body with the 10 plastic flat head screws M10 x 25 (4) and gaskets (3).

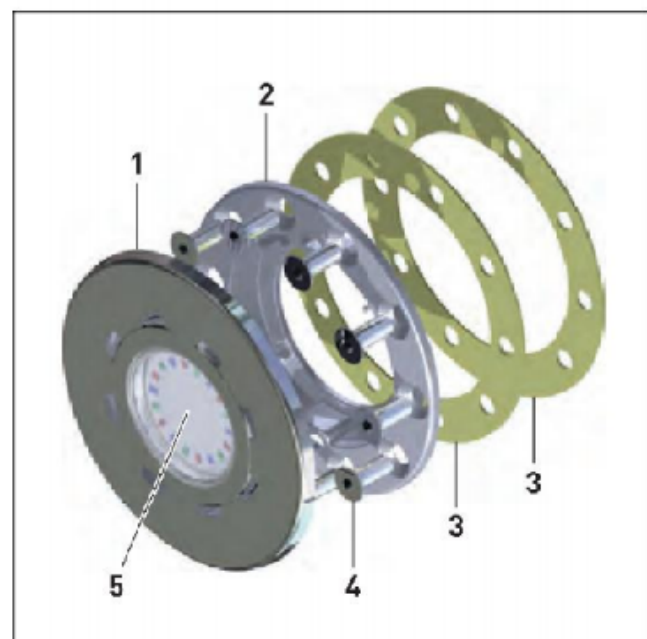

- Press the smart lamps illuminator (5) into the deepening in the middle of the mounting flange and store the surplus power cable into the remaining space in the mounting niche.

- Finally, fasten the cover plate (1) to the front side of the flange with the two mushroom-shaped bolts (see detail A). Place the bolts into the holes and turn them clockwise until the bolts snap in. For this step a modest force must be applied. The enclosed special turning tool (see detail B) helps to make this easier.

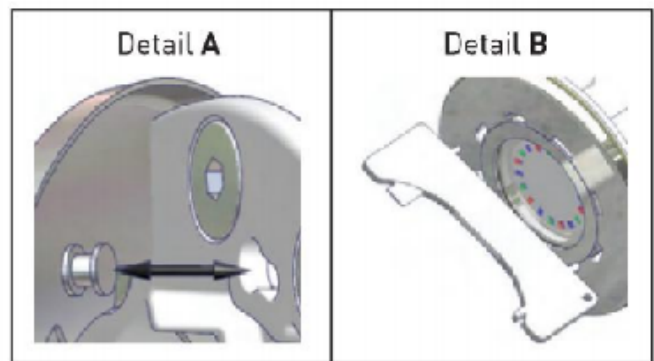

- Alternatively, an adequately sized spreading pliers can be used.

## 5.5 Installation with a 1.5" wall outlet



### CAUTION!



Please remove the rubber O-ring of the smart lamps illuminator with utmost care in order to avoid damages to the housing. The O-Ring is not needed any more and can be disposed.

- Remove the circumferential round rubber ring (1) at the side of the smart lamps (R) illuminator (2). If necessary, use a screwdriver or a knife for that purpose.

- First put the O-Ring (6) into the adapter ring, then push the smart lamps illuminator (R) forward into the adapter ring (3), whilst the IP 68 connector cable (5) is fed through the center hole. The illuminator must be snapped into the adapter and should be flush afterwards. Make sure that the retaining tabs correspond to the recesses provided in the Illuminator's side.

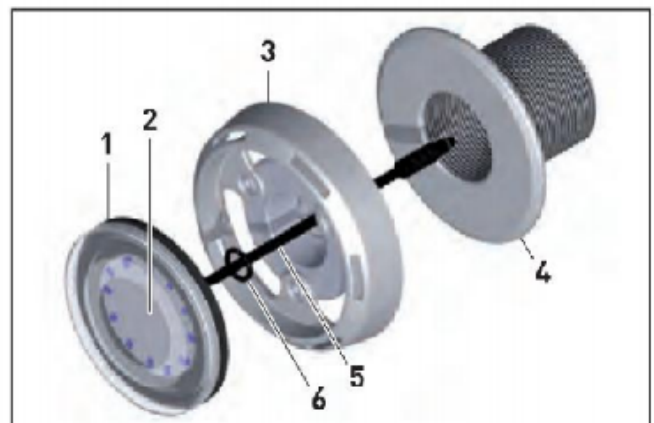

- Connect the IP 68 cable on the illuminator with its counterpart within the 1.5" wall inlet nozzle (4) connect secure it with the protective sleeve. See Section 5.6 cable protection with by protective sleeve.



### CAUTION!



Please apply only moderate force to the adapter ring to prevent the threads from damage!

- Screw the adapter ring with the snapped-in illuminator into the 1.5" wall inlet nozzle. Stow away the excess power cord inside the inlet's body.
- For disassembly or separation of the adapter ring from illuminator, press the retaining plates aside with a screwdriver [see figure].

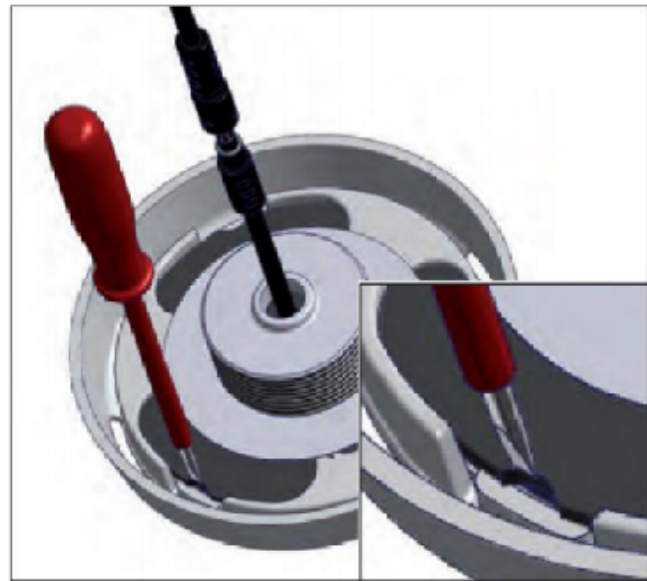

## 5.6 Cable protection with protective sleeve



### CAUTION!



**Do not open the protective sleeve nor the IP 68 connectors under water. The result would be ingress of water and the destruction of the connector!**

In case of aggressive water conditions, the IP 68 connector should be mounted with an additional protective sleeve. Proceed as follows:

- Dismantle both bayonet IP 68 cable connectors [2 and 3].
- Separate the included two-piece protective sleeve (1) as shown in the image below. Slip the sleeve over the IP 68 cable connector.
- Fix both halves of bayonet IP 68 cable connector (2 and 3) together again and turn it clockwise until it is properly locked and snapped in. Please make sure that the O-ring is attached to the male connector.
- Tighten the screws of protective sleeve.

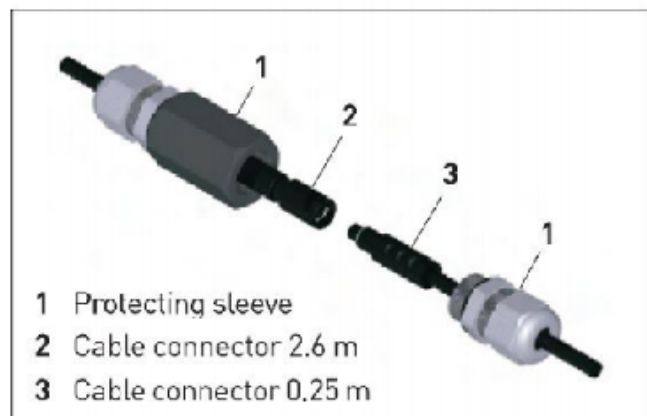





## HINT!



These operations must always be carried out over the water's surface so that there is air in the protective sleeve.

### 5.7 Cable Extension

For the replacement of an existing illuminator, it is usually necessary to join the existing cable in the mounting niche with the connection cable of the smart lamps illuminator.

There are several options:

- ▶ Complete replacement of the connecting cable
- ▶ Cable extension using water-tight heat shrink tubing
- ▶ Cable extension with epoxy cast resin
- ▶ Cable extension with gel joint



## HINT!

In case of a complete replacement of the connecting cable, it is advisable to shorten the included 2.6 m connection cable to approximately 1 m length so that it fits better into the old existing niche.

## 6. Electrical installation



## CAUTION!



- ☞ The entire planning, construction and retrofitting of electrical installations must be carried out only in accordance with your country's relevant standards!
- ☞ All work in low-voltage installations must be performed by a qualified electrician only (in Germany according to VDE 0100). The applicable accident prevention regulations must be observed!
- ☞ To avoid electric shock, all circuit breakers and fuses have to be switched off prior to any type of work at the installation!
- ☞ All installation work must be carried out by a skilled electrician only!
- ☞ Replacement cables must have sufficient cross section.

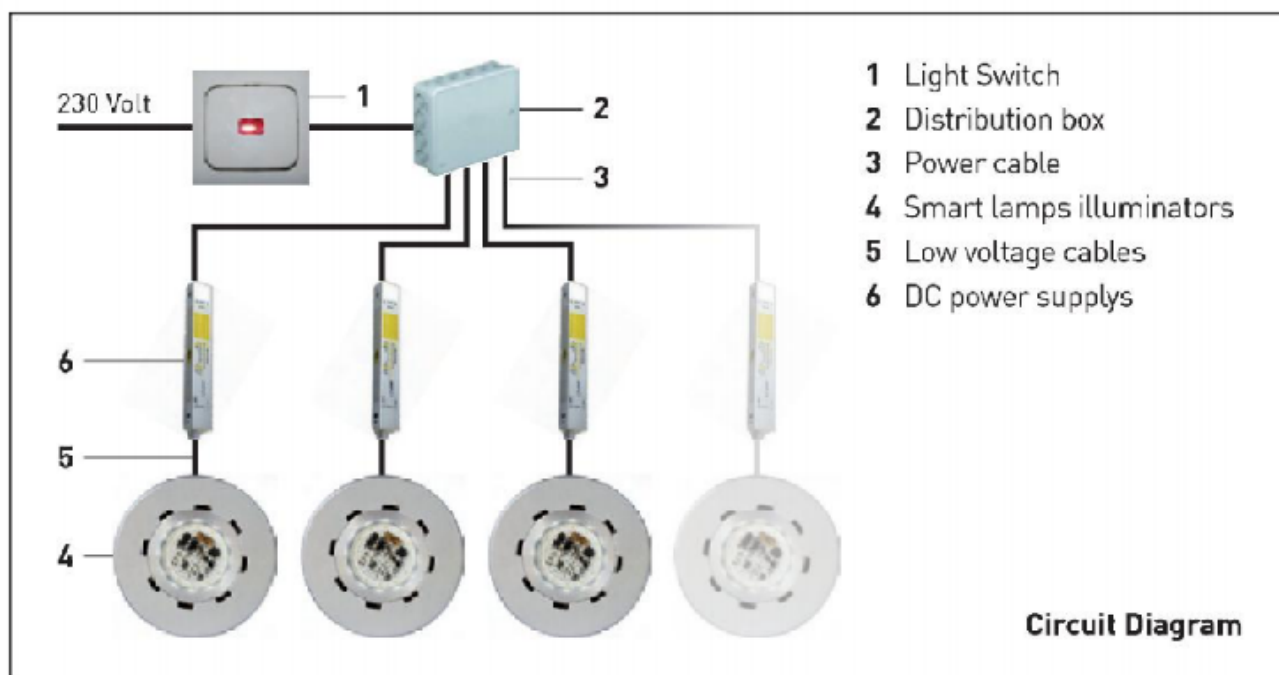

- ☞ Place the power supplies in a dry area outside the danger zone (min. 3 m), e.g. in an installation cabinet and run the low voltage cables in the shortest possible manner to the individual illuminators.
- ☞ The temperature of the power supply units must not exceed the maximum of 40 °C. Air circulation must be guaranteed on 3 sides.



### CAUTION!

**Stacking the units or putting them in rows is not permitted and causes overheating.**

- ☞ If you need more than one power supply, connect them in parallel and attach them to the 230 V mains with a single regular power switch (see drawing circuit diagram).
- ☞ The power supplies should be fitted in the vicinity of the illuminators. However, in most cases it will be necessary to extend the supplied 2.6 m connection cable. For this purpose, use commercial electrical installation cable. Up to a cable length of 10 m a cable cross-section of 1.0 mm<sup>2</sup> is enough, for lengths of 20 m 1.5 mm<sup>2</sup>. For cable lengths larger than 20 m it is recommended to use a cross-section of 2.5 mm<sup>2</sup> to achieve the lowest possible power losses. It is not advisable to use lengths in excess of 30 m.

## 7. Operation instructions



### CAUTION!



The system may only be put into operation when all mechanical and electrical works have been carried out properly by a professional electrician and after having been carefully tested.

- To switch the smart lamps illuminators into operation, flip the light switch (Pos 1 in circuit diagram) into position „ON“.
- To switch the smart lamps illuminators out of operation, flip the light switch (Pos 1 in circuit diagram) into position „OFF“.



### HINT!

Other steps to switch on or off are not necessary.

## 8. Troubleshooting



### CAUTION!



If major deviations from normal condition are found during operation, turn off the smart lamps illuminators and seek a competent expert for fault clearance.

Perform troubleshooting and remedies as per table below:

Type of malfunction	Possible cause	Remedy
No function of smart lamps illuminators.	230 V fuse blown.	Check 230 V fuse and replace if necessary.
	Interruption in the power supply.	Check transformer(s) and feed lines by competent expert.
	Illuminator defect.	Exchange illuminator by competent expert.

Type of malfunction	Possible cause	Remedy
Illuminators shine, but too weak.	Inadequate cooling.	Water temperature is too high, maximum of 37 °C is permissible. Lower water temperature.
	Faulty installation, heat dissipation surfaces blocked.	Make sure that the heat dissipation surfaces are freely accessible.
	Cooling water circulation is obstructed.	Remove pollution, algae or similar obstructions.
	LED's lose luminosity during operation time. The maximum burning time of approximately 10,000 hours is reached.	Exchange illuminator by competent expert.
Illuminators flicker.	Loose connection in the electrical circuit or corrosion of contacts.	Check all electrical connections and cables by competent expert and replace if necessary.
	Faulty transformer.	Measure current and voltage of the trafos. In case of deviations from the normal values replace through a competent specialist.
	Voltage losses due to long power cable.	Check voltage at the illuminator and if necessary, install cable with a larger cross-section through a competent specialist.  <b>In case of all other disturbances or irregularities switch off power immediately and contact a competent expert.</b>

## 9. Guarantee and Limited Warranty

- ☞ The "Warranty Conditions for smart lamp products" have to be observed. These can be viewed separately at [www.bvrelectronic.de](http://www.bvrelectronic.de) under the navigation point "download".
- ☞ All products and components have to be wired and installed properly, together as a system.
- ☞ Combination of smart lamp's product components with those of other manufacturers are strictly forbidden, especially with power supplies.
- ☞ It is absolutely essential to use only original smart lamps transformers for illuminators. They are adapted in voltage and power to work with our product. If transformers other than the original units are used, functional damages might occur and no warranty can be given by BvR electronics GmbH. It can even be a severe safety risk to yourself.
- ☞ Presence of conditions demonstrating abnormal use or stress, including under/over voltage, power spikes in the grid, excessive switching cycles, excessive operating hours, frost, extreme UV radiation, extreme level of pool chemicals (chlorine, nitrate, fluoride, phosphate), alterations, forces of nature, act of God, theft, misuse, abuse and damages caused by negligent installation, improper maintenance or where adequate care has not been taken to prevent damage to the lighting system voids all warranty and product liabilities of BvR electronics GmbH.
- ☞ The customer is responsible for compliance with the required water quality. BvR electronics GmbH rejects all warranty and liability for non-compliance of water parameters.
- ☞ Moisture or water seepage into the smart lamps illuminators is not necessarily a dysfunction, the lamps will continue to function properly. The products have multiple water barriers so that the ingress of moisture does not impact the performance of the illuminators.
- ☞ Due to the constantly changing availability and improvement of electronic parts such as capacitors, diodes and switching regulators, all technical data, especially the light color and the color effects, cannot be guaranteed for future products. All technical data are explicitly subject to change.
- ☞ The illuminator's surface is coated with a special ceramic material ("Hard-coating") for corrosion protection purposes. Even a minor injury of this protective film can lead to immediate start of corrosion processes of the housing under certain water conditions. Therefore, please make sure that the illuminator's surface is not scratched or damaged. Warranty is always excluded in this case.